

# SHAVER

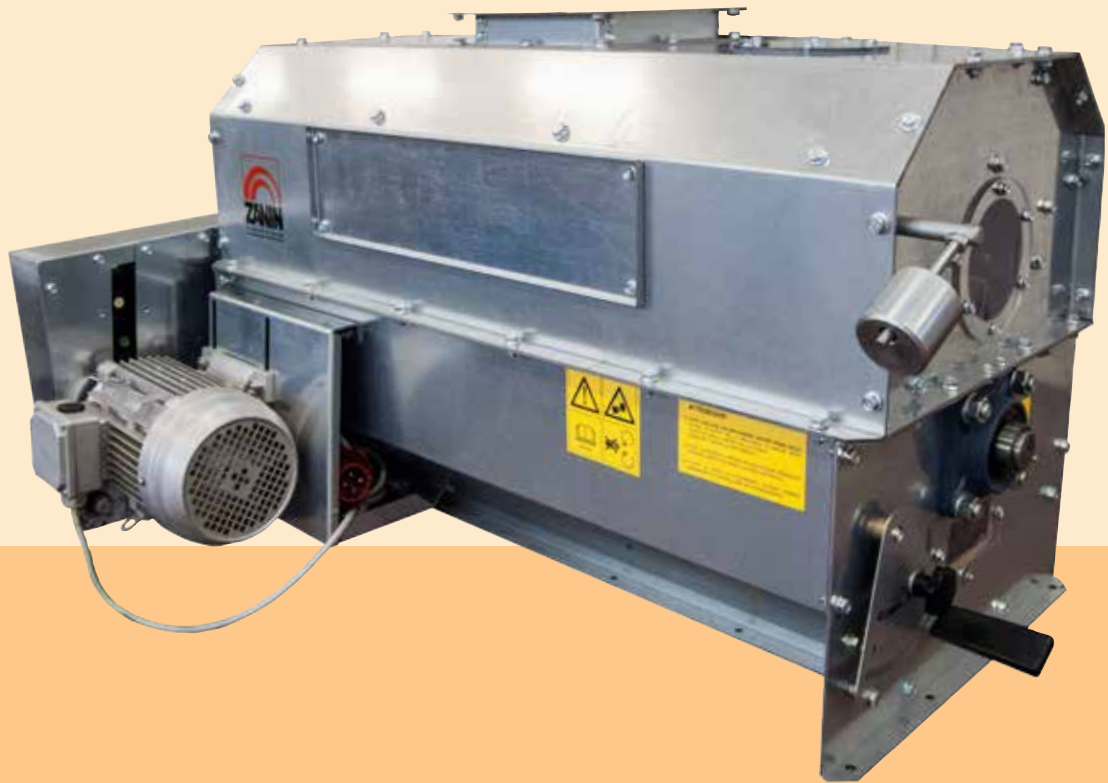

## USE

The function of the shaver is to remove in a short time the parts (tips) present in the cereal.

## OPERATION

The product enters by gravity into a dosing hopper and is distributed evenly over its entire width.

The product falls onto a sieve and a vibrating force with a combination of an air flow separates the heavy bodies that will go upward and the product falls downwards.

## MANUFACTURING

- Metal sheet with galvanised metal sheet sections tank support framework
- Hemmed edge tank, bolted among the various elements that make it up
- Adjustable bars rotor
- Product inlet hopper, with equaliser flow.
- Conveyor drive.



01



02



03

**DETAILS**

- 01) Motorization
- 02) Control porthole
- 03) Manual adjustable product outlet

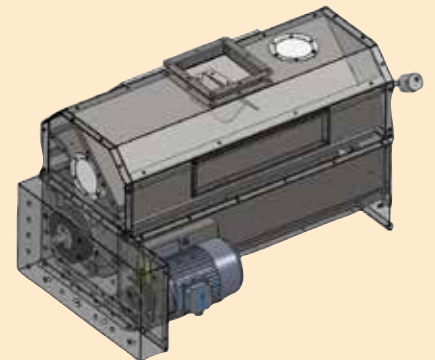
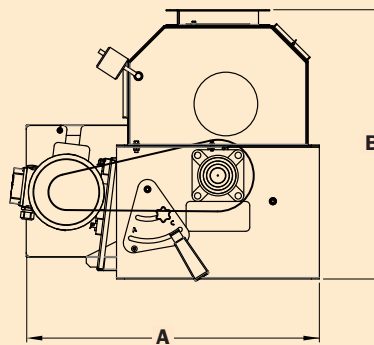
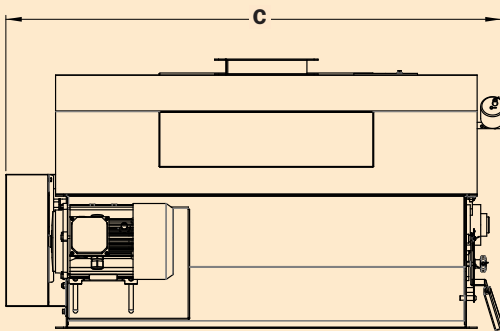

MODEL	CAPACITY t/h	POWER kW	A mm	B mm	C mm
SB-2	2	2,2	737	697	1245

**NB:** Capacity with wheat specific weight 0.78 t/m<sup>3</sup> - 14% relative humidity - 2% impurities



**ZANIN F.lli s.r.l.** Viale delle Industrie, 1 - 31032 Casale sul Sile (TV) - Italy  
 Tel. +39 0422 785444 - Fax +39 0422 785805  
 www.zanin-italia.com info@zanin-italia.com



© 2015 ZANIN F.lli - WARNING: DATA NOT BINDING, PLEASE REFER TO THE TECHNICAL DATA RELEASED DIRECTLY FROM ZANIN F.LLI

ZANIN-09-06-15

**RESELLER**