



AIR SEPARATOR

ZANIN F.lli s.r.l.
 Viale delle Industrie, 1
 31032 Casale sul Sile (TV) - Italy
 T. +39 0422 785444
 F. +39 0422 785805
 www.zanin-italia.com
 info@zanin-italia.com



RESELLER

©2014 ZANIN F.LLI - All contents (text, photos, graphic) present in this brochure are propriety of the ZANIN F.LLI company and are protected by the current law. The brochure cannot be published, reproduced, rewritten, distributed, and commercialized without explicit authorization. Brands, denominations and the mentioned companies inside of this brochure are propriety of respective proprietors and are protected by the current law in matter of brands, patents and / or copyright.
 The company Zanin F.lli disclaims any liability for any inaccuracies in this depliant and reserves the right to make changes to the product as it deems appropriate at any time and without notice.

WARNING: INFORMATION IS NOT BINDING, PLEASE REFER TO THE TECHNICAL DOCUMENTATION RELEASED DIRECTLY BY ZANIN F.LLI



SA

AIR SEPARATOR

The separator permits to separate good product from by-products and/or waste, confirm of different spec. weights.



FUNCTION

The product enters by gravity in a rotating distributor and is distributed uniformly of the entire width. The product is invested by a transversal airflow, and fall more or less far-

off in the unloading hoppers on the basis of spec. weight. The machine works free blowing.

Mod. SA 60-100

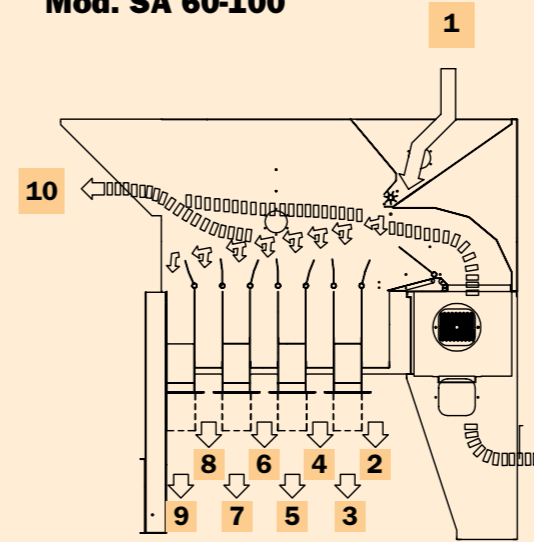

LIGHT ← → HEAVY

Mod. SA 150-200

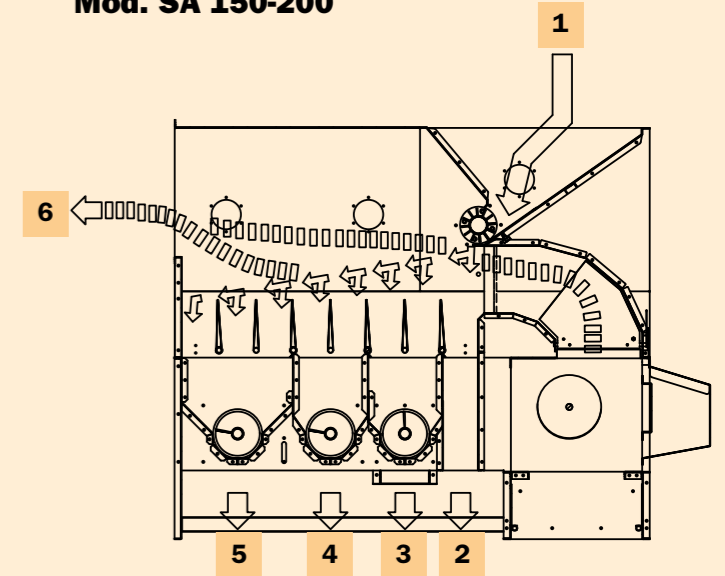

LIGHT ← → HEAVY

Mod. SA 60-100

- 1 Product with impurities inlet
- 2 I separation outlet
- 3 II separation outlet
- 4 III separation outlet
- 5 IV separation outlet
- 6 V separation outlet
- 7 VI separation outlet
- 8 VII separation outlet
- 9 VIII separation outlet
- 9 Dust exit

Mod. SA 150-200

- 1 Product with impurities inlet
- 2 I separation outlet
- 3 II separation outlet
- 4 III separation outlet
- 5 IV separation outlet
- 6 Dust exit

CONSTRUCTION

- Cowling in pressed galvanized sheet
- Regulation airflow shutter
- Shutter for product selection
- Unloading hopper



- 01) Airflow outlet
- 02) Side view
- 03) Separator Mod. SA 200 with cyclone
- 04) Airflow intake
- 05) Unloading hoppers
- 06) Unloading from hoppers



| MODEL | SA 60 | SA 100 | SA 150 | SA 200 |
|-------------------------|-------|--------|--------|--------|
| Output - t/h * | 1,2 | 3 | 5 | 12 |
| Roller motor power - kW | 0,25 | 0,25 | 0,25 | 0,25 |
| Fan power - kW | 1,5 | 3 | 4 | 3x1,5 |
| Length - mm | 2837 | 2840 | 2340 | 2335 |
| Width - mm | 830 | 1230 | 2090 | 2580 |
| Height - mm | 2320 | 2320 | 2320 | 2320 |
| Weight empty - kg | 380 | 500 | 800 | 900 |

* output with wheat specific weight 0,78 t/m³ - RH 14% - 2% impurities.

OPTIONAL

- Moving wheels
- Electrical panel
- Inverter
- Collecting case