

MECHANICAL BAGGING MACHINE



USE

For powders or granular flowing, for bags or containers that are opened. Weighed by 5 to 50 kg, 120 to 350 weighings / hour (50-5 kg).

MANUFACTURING

- Made of stainless steel
- Weighing system certified
- Easy to use
- Minimum maintenance
- Foot switch

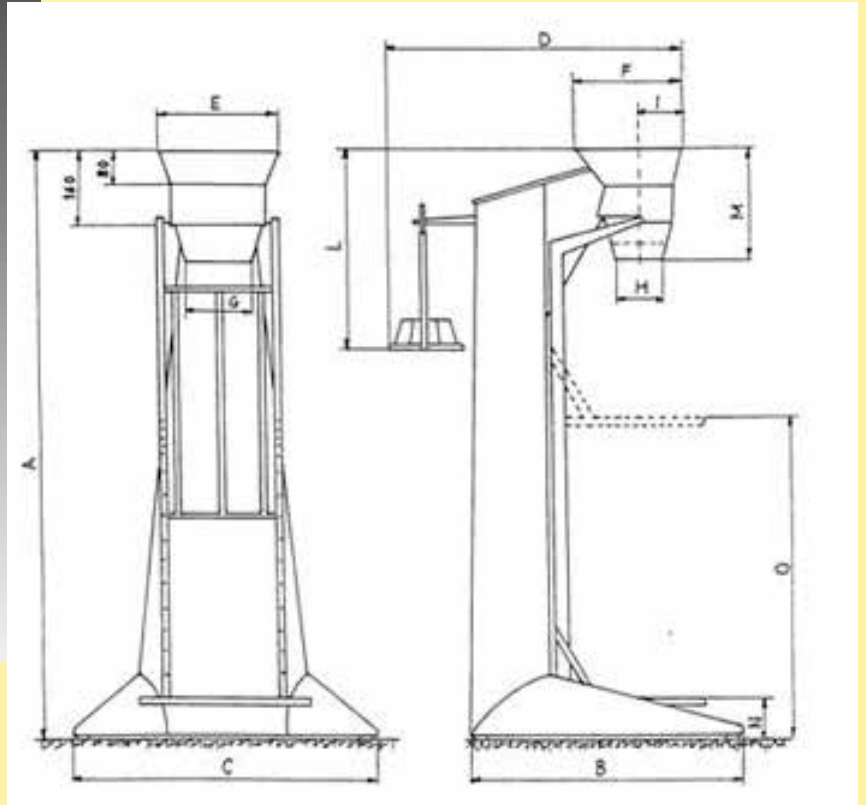

MODEL	A mm	B mm	C mm	D mm	E mm	F m ³	G mm	H mm	I mm	L mm	M mm	N mm	O mm
P50	1280	600	670	700	270	240	150	100	100	450	240	100	700
P50V	1280	600	670	700	270	240	180	130	100	450	240	100	700



ZANIN F.lli s.r.l. Viale delle Industrie, 1 - 31032 Casale sul Sile (TV) - Italy
 Tel. +39 0422 785444 - Fax +39 0422 785805
 www.zanin-italia.com info@zanin-italia.com



© 2015 ZANIN F.lli - WARNING: DATA NOT BINDING, PLEASE REFER TO THE TECHNICAL DATA RELEASED DIRECTLY FROM ZANIN F.LLI

ZANIN-13-06-15

RESELLER