

# HORIZONTAL MIXER

The horizontal mixer ensures perfect mixing of products in powder or granular even with different specific weights and dosed with the addition of liquid components; thanks to the special design of the system homogenizing discontinuous based on a single reel double concentric coil, suitably dimensioned for the toughest jobs for these reasons it is successfully used in various industrial sectors.



## DETAILS

- 01) Mixer with belt drive
- 02) Loading auger detail
- 03) Mixer with weighing load cells



# OPERATION

The horizontal mixer, can be used for a wide range of applications, also the most demanding. The design of the homogenizing system presents a tub of ideal shape to follow the internal movement of the product during the mixing phase, with double concentric reel principle and a system perfectly dimensioned so as to avoid unnecessary dead zones. It can be built either in painted carbon steel or stainless steel AISI 304 / AISI 316 and is designed and

built to meet specific customer requirements, such as: special overall dimensions, connection to existing machinery, capacity and production requirements, engine power and motion transmission to the mixing reel which are suitably dimensioned and applied, resulting in the realization of a machine perfectly corresponding to customer's demands.

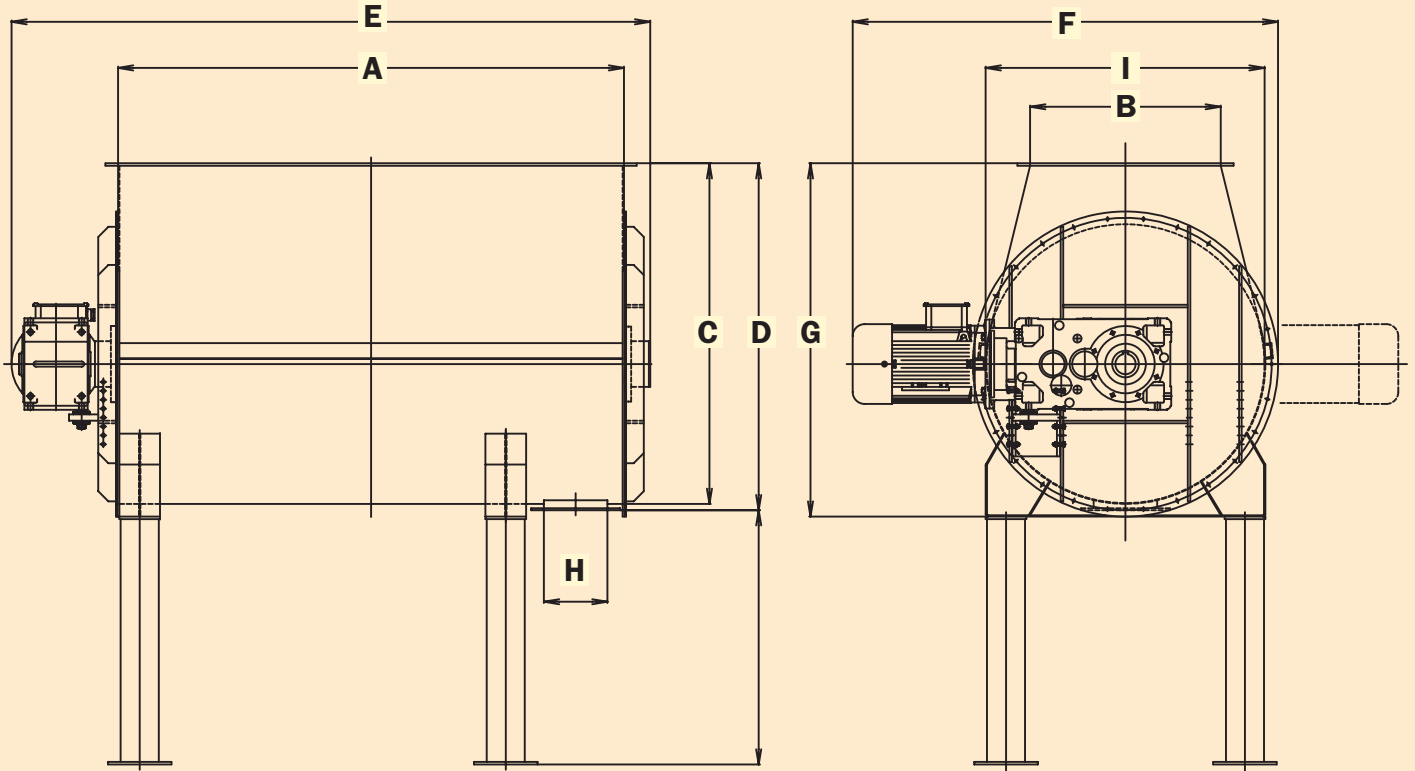

WORKING CAPACITY liters	A mm	B mm	C mm	D mm	E mm	F mm	G mm	H mm	I mm	POWER kW	CAPACITY kg	WEIGHT kg
500	1246	745	910	925	1650	950	950	250x250	745	3	250-350	420
1000	1496	650	1080	1095	1980	1330	1125	250x250	900	5,5/7,5	500-700	580
2000	1996	750	1340	1355	2480	1440	1390	250x250	1100	7,5/11	1000-1400	1020

## OPTIONAL

- Electro-pneumatic unloading mechanism
- Pre-load hopper
- Total discharge "bucket" electro-pneumatically controlled
- Under hopper with screw extractor
- Pipe with nozzles spraying liquids
- Electronic weighing system with load cells
- Dosing programs with digital display or computerized
- Execution in compliance with ATEX 94/9 / EC

## FEATURES

- Working capacity: 500 - 1000 - 2000 liters
- Execution in painted carbon steel or stainless steel AISI 304 or 316
- Direct transmission with helical gear motor or with chain drive
- Mixing system composed by advancing counter-rotating masses, converging based on double reel concentric coil mounted on tree with cast iron supports
- Mixing procedure is rapid and effective



**ZANIN F.lli s.r.l.** Viale delle Industrie, 1 - 31032 Casale sul Sile (TV) - Italy  
 Tel. +39 0422 785444 - Fax +39 0422 785805  
 www.zanin-italia.com info@zanin-italia.com



©2015 ZANIN F.lli - WARNING: INFORMATION IS NOT BINDING, PLEASE REFER TO THE TECHNICAL DOCUMENTATION RELEASED DIRECTLY BY ZANIN F.LLI

ZANIN-02-03-15

## RESELLER

