



CYLINDRICAL FILTER



USE

The cylindrical body filters are designed particularly for use in pneumatic conveying lines.

OPERATION

The air product mixture enters tangentially in the lower part of the body that contains the sleeves; by cyclonic effect the heavier particles fall towards the bottom, while the lighter parts ascend back upwards with the air in the direction of the filtering sleeves. The latter are crossed through by the air and are forced to place themselves against their own framework, so that their cross-section is configured as the perimeter of a star. The cleaned air passes through among the chambers, in a timed pressure cycle, through a valve. The cleaning action is then completed by the air that continues for some time to flow through the fabric, air that is taken from the other sleeves in the filtering stage and conveyed to the filter outlet.

MANUFACTURING

- AISI 304/316 carbon steel or stainless steel cylindrical body
- Inspection side portholes and replacement of sleeves
- Cotton, polyester fibres, polyamide fibres, glass fibres filtering sleeves

OPTIONAL

- Flanged cylindrical body for direct mounting on silos, tanks, etc.
- Pallet bottom extractor for difficult products or matters relating to space
- Discharge cone and support legs
- Protection hood against atmospheric elements for outdoor installation,

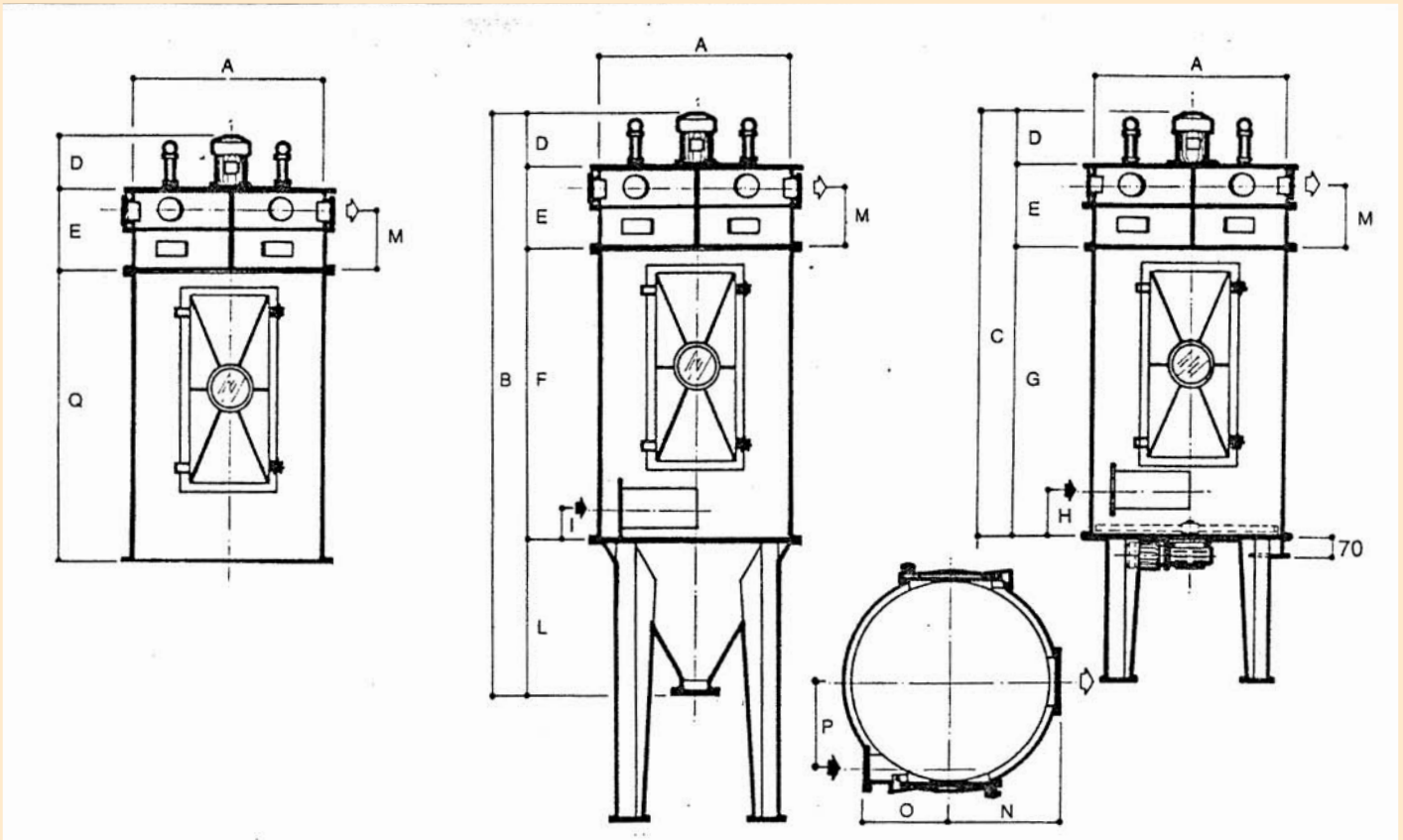

| MODEL | | 3/3,5 | 6/10 |
|------------------|----------------|-------|-------|
| A | mm | 700 | 1193 |
| B | mm | 2705 | 3053 |
| C | mm | 2545 | 2533 |
| D | mm | 290 | 290 |
| E | mm | 415 | 413 |
| F | mm | 1400 | 1400 |
| G | mm | 1830 | 1830 |
| H | mm | 560 | 560 |
| I | mm | 130 | 155 |
| L | mm | 600 | 950 |
| M | mm | 259 | 303 |
| N | mm | 350 | 609 |
| O | mm | 300 | 500 |
| P | mm | 310 | 521,5 |
| Q | mm | 1200 | 1200 |
| Filtering Area | m ² | 3,5 | 10 |
| N° Air lines | | 6 | 18 |
| Ventilator power | kW | 1,5 | 3,0 |
| Compressed Air | NI/I' | 16 | 20 |
| Weight | kg | 310 | 860 |



RESIDUES PALLET EXTRACTOR



ZANIN F.lli s.r.l. Viale delle Industrie, 1 - 31032 Casale sul Sile (TV) - Italy
 Tel. +39 0422 785444 - Fax +39 0422 785805
 www.zanin-italia.com info@zanin-italia.com



© 2015 ZANIN F.lli - WARNING: DATA NOT BINDING, PLEASE REFER TO THE TECHNICAL DATA RELEASED DIRECTLY FROM ZANIN F.LLI

ZANIN-09-06-15

RESELLER