



Since 1956

THE QUALITY OF EXPERIENCE
ON INDUSTRIAL SERVICE



CHAIN CONVEYOR



industry



The Company Zanin F.lli was founded in 1956.

We specialise in the production of complete systems for cleaning, drying, handling and storing cereals.

Our Company rapidly grew to gain a position of excellence on the international market, backed by its values: constant commitment to innovation, client assistance, flexibility, enhancement of human resources and competitiveness.

Zanin F.lli provides the agro-food industry with its relentless research and virtuous, continual personnel training.

In this way we have developed very high specialisation and a total quality process with TÜV SÜD certification.

All Zanin F.lli products therefore guarantee constant results and increasingly better performance.

CHAIN CONVEYOR

The chain conveyor is used for granular products transportation. It is used for transferring in length products that need to be transported in silos, working towers, process machines, fast loads. It is indicated for all sliding products, with varying capacities; it is reliable and airtight.



PLANTS FOR GRANULATED AND FLOURS LIVENING *PORTO MARGHERA - VENEZIA*



PLANTS FOR GRANULATED AND FLOURS LIVENING PORTO MARGHERA - VENEZIA



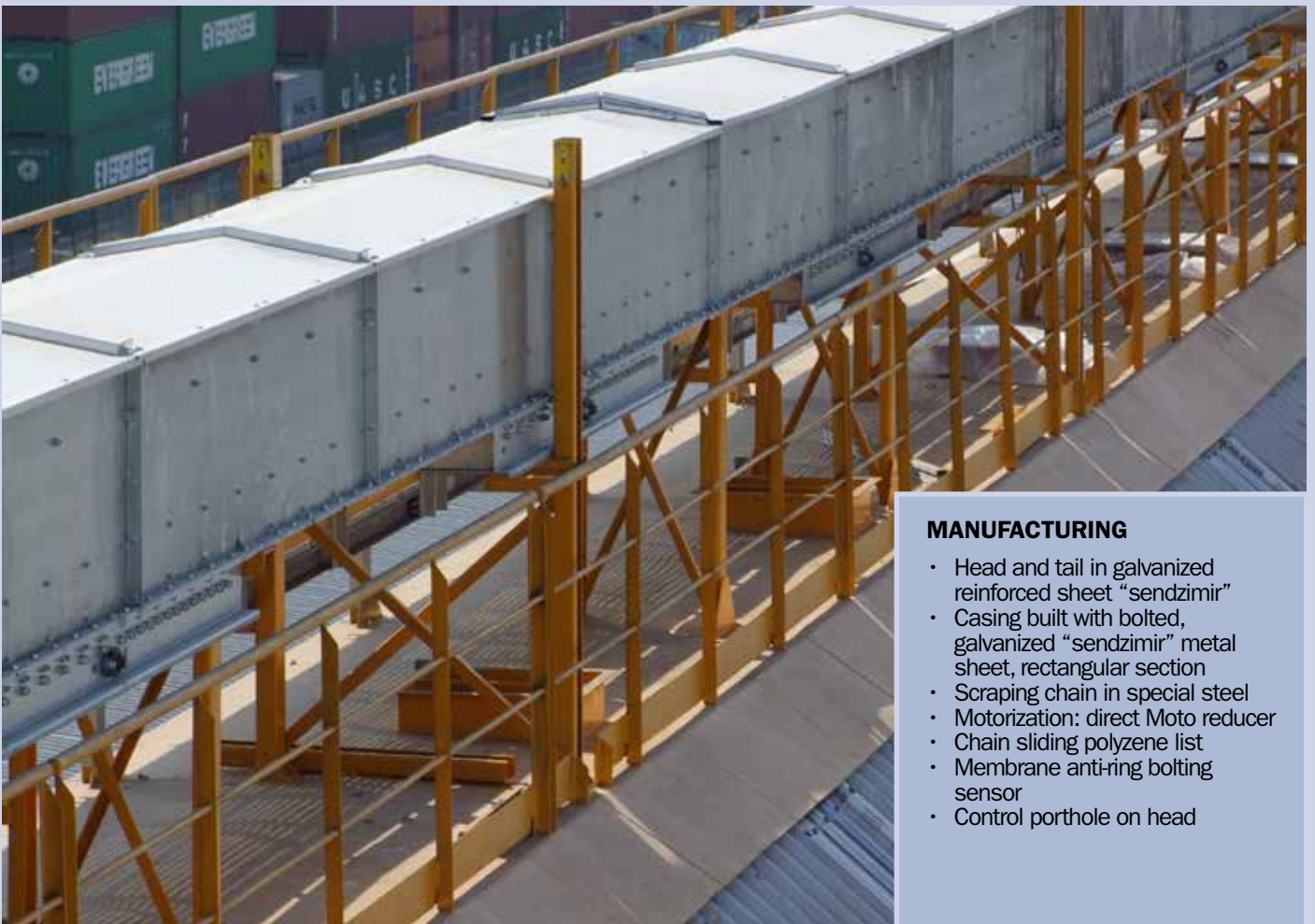

MANUFACTURING

- Head and tail in galvanized reinforced sheet “sendzimir”
- Casing built with bolted, galvanized “sendzimir” metal sheet, rectangular section
- Scraping chain in special steel
- Motorization: direct Moto reducer
- Chain sliding polyzine list
- Membrane anti-ring bolting sensor
- Control porthole on head

OPERATION

The product enters for gravity, a chain linear movement make move the product towards the loading opposite side and it is released in an unloading hopper (optional). The capacity is given from the chain speed.

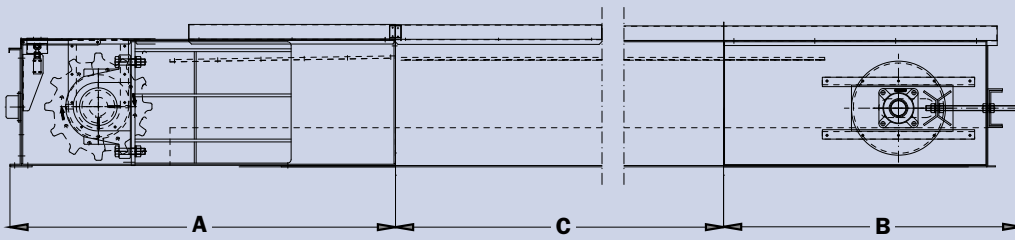
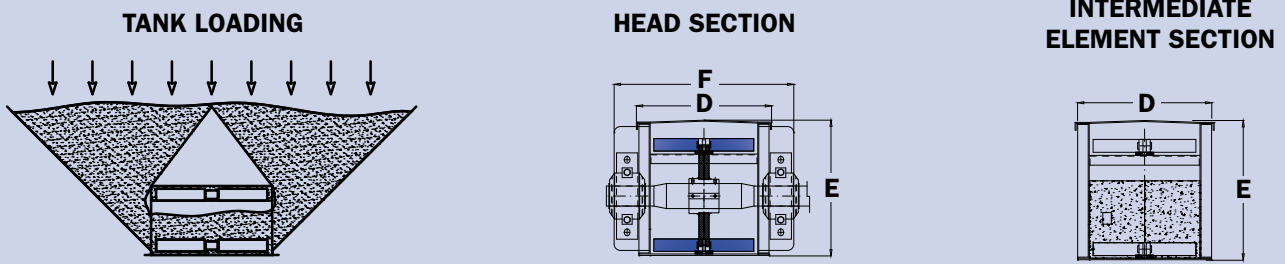

DETAILS

- 01) Forged chain
- 02) Stamped chain
- 03) Nylon chain
- 04) Double scraping chain

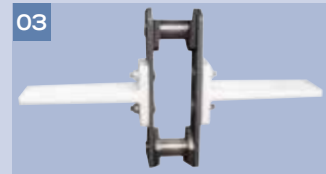

FORGED CHAIN

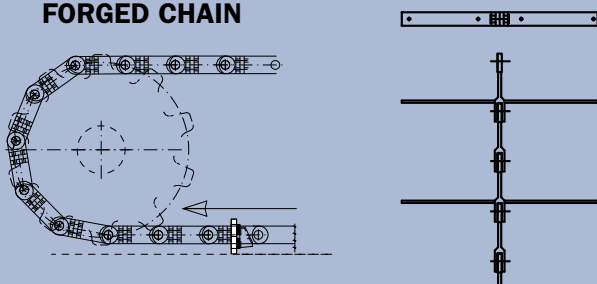

STAMPED CHAIN

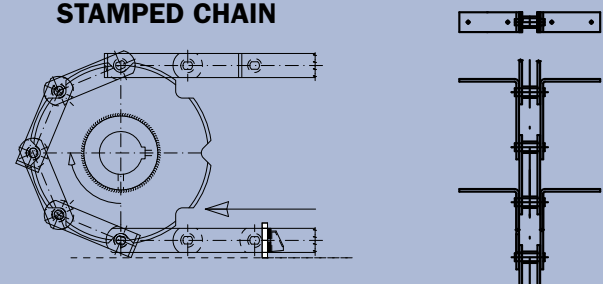

MODEL	CAPACITY t/h	SPEED m/s	A mm	B mm	C mm	D mm	E mm	F mm
TAC-I 340-120	120	0,53	1000	1000	1940/2940	400	435	640
TAC-I 340-150	150	0,70	1000	1000	1940/2940	400	435	640
TAC-I 430-180	180	0,53	1000	1000	2910	520	540	730
TAC-I 430-250	250	0,70	1000	1000	2910	520	540	730
TAC-I 530-340	340	0,55	1000	1000	2910	620	740	1000
TAC-I 530-430	430	0,70	1000	1000	2910	620	740	1000
TAC-I 650-400	400	0,53	1500	1500	2910	740	740	1120
TAC-I 650-530	530	0,70	1500	1500	2910	740	740	1120
TAC-I 800-490	490	0,53	2000	2000	2910	890	740	1270
TAC-I 800-650	650	0,70	2000	2000	2910	890	740	1270
TAC-I 1200-710	710	0,53	2000	2000	2910	1240	740	1620
TAC-I 1200-950	950	0,70	2000	2000	2910	1240	740	1620

N.B.: The models showed in the table are available in CS and CF version, in accordance with the used chain type. For capacities from 40 to 120 t/h see Agro industrial catalogue. Data and specifications calculated with a product specific weight 0,78 t/m³. Capacity has been calculated with transporters in horizontal position. The company declines every responsibility regarding the data care in this brochure and reserves the right to modify the product as necessary.

OPTIONAL: Motor with chain transmission / Moto changer / Inverter / Revolutions control / Loading hopper / Unloading hopper / Anti-burst panels / Forged chain / Hardox anti-wear plate on container bottom width / Anti-wear plate / Polyzene on container bottom width / RAL painting on request / Hot galvanizing / Stainless steel AISI 304/316.



- ACCESSORIES**
- 01) Motorization head with direct transmission
 - 02) Conveyor head with joint
 - 03) Conveyor head with chain
 - 04) Conveyor tail
 - 05) Revolution control sensor
 - 06) Overload sensor
 - 07) Forged chain
 - 08) Towing wheel for stamped chain
 - 09) Towing wheel for forged chain
 - 10) Chain conveyor sight
 - 11) Section drawing with particular self-cleaning
 - 12) Product unloading shutter

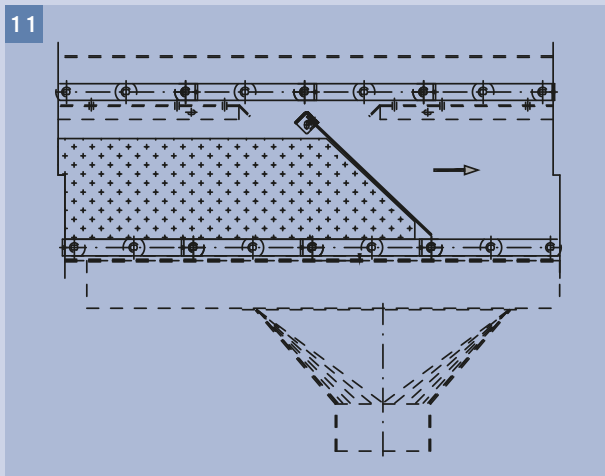

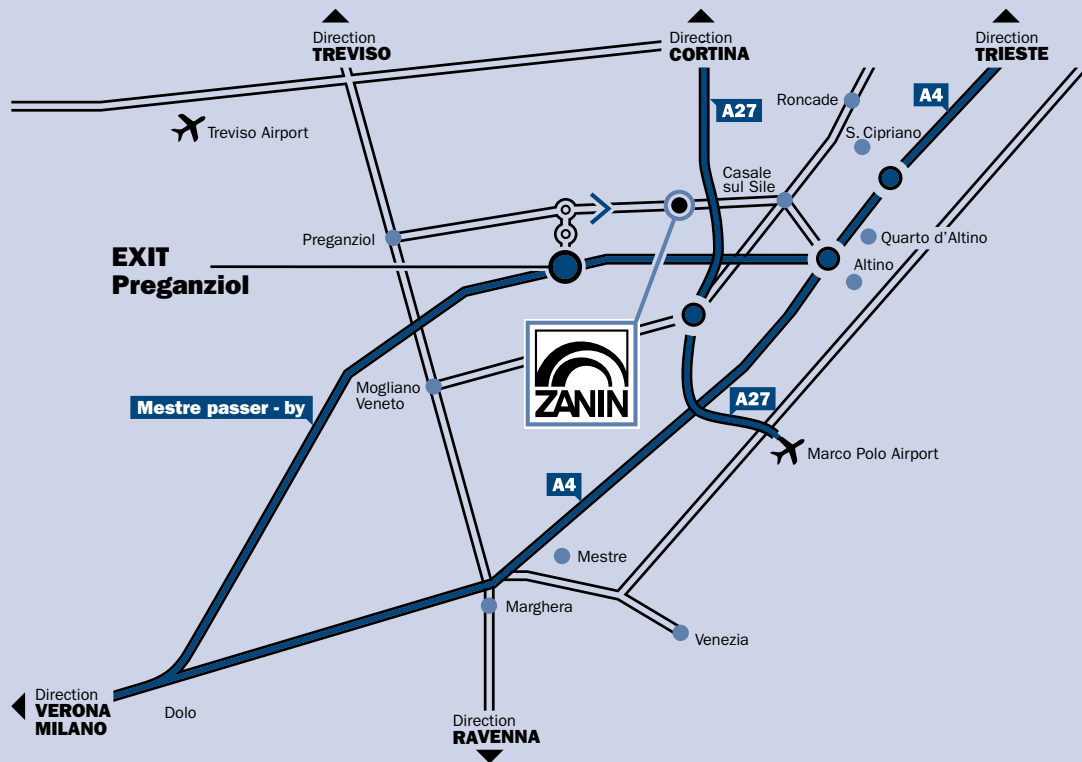

Photos by Glauco Granatelli, Walter Coledan, Dicaprio Veronica, Didier Descouens, Maik-T. Šebenik



ZANIN F.lli s.r.l.
 Viale delle Industrie, 1
 31032 Casale sul Sile (TV) - Italy

T. +39 0422 785444
 F. +39 0422 785805

www.zanin-italia.com
 info@zanin-italia.com



©2015 ZANIN F.LLI - All contents (text, photos, graphic) present in this brochure are propriety of the ZANIN F.LLI company and are protected by the current law. The brochure cannot be published, reproduced, rewritten, distributed, and commercialized without explicit authorization. Brands, denominations and the mentioned companies inside of this brochure are propriety of respective proprietors and are protected by the current law in matter of brands, patents and / or copyright. The company Zanin F.lli disclaims any liability for any inaccuracies in this depliant and reserves the right to make changes to the product as it deems appropriate at any time and without notice.

WARNING: INFORMATION IS NOT BINDING, PLEASE REFER TO THE TECHNICAL DOCUMENTATION RELEASED DIRECTLY BY ZANIN F.LLI

RESELLER